



NOPR

Olympic Power Rack

**NOPR
Olympic Power Rack**

Steelflex® NOPR is ideal home and commercial used power rack, you could do Barbell squat, T-Bar Row, Chin Up, Rubber band training, etc. all in one NOPR, get one for your home or gym.

SPECIFICATIONS

- A. Mainframe: Heavy-Gauge 1.968" X 3.937" oval tubing (50 x 100 x 2.5T mm)
- B. Eight Rubber Band Rack- extend your power squat training extra option.
- C. Six Olympic Storage weight posts with ergonomic angle design - keeping your workout area clutter free, and taking Plate smoothly and easily.
- D. 1/4" zinc plated solid gunracks
- E. One Olympic Bar hole-no more messy weight trees or weights on the floor!
- F. One T-Bar Row Platform with two hole could switch place.
- G. Chin up bar- full of your power center
- H. Product Weight:385 lbs / 175 kg
- I. Dimension: 83" L x 68" W x 91.5" H (211 cm x 174 cm x 232 cm)
- J. Packing: 3 Cartons, 33.6 Cubic Feet
- K. Optional:
 OB-86 Olympic Bar
 WRO Olympic Rubber Weight plate
 OC-06 Olympic Spring Collar
 LBB-28 Lat Blaster Bar

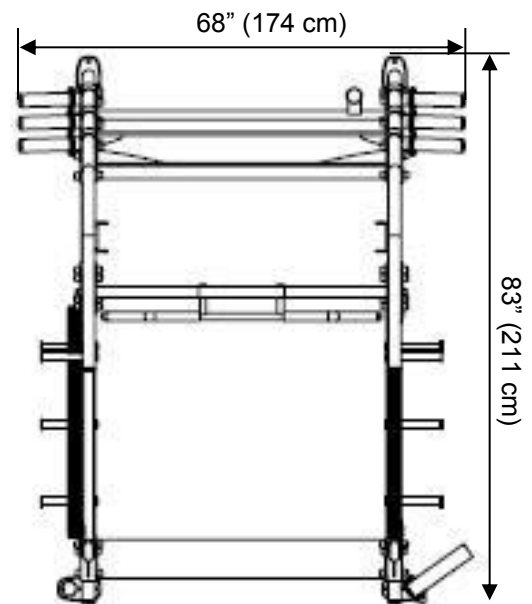

**Fitness Master Inc. • 11419 Mathis #200 • Farmers Branch, Texas 75234
 Tel: 214.350.8884 • Toll Free: 1.855.846.0087**