



Product Data Sheet

CLPR-380

Club Line Power Rack 380 with Monkey Bar

Freedom of movement combined with front and rear frame, 14-position gunrack can handle over 1,000 lbs. and gives the user the ability to walk the bar up and down without removing plates. Adjustable safety positions make this Club Line Power Rack a must-have for those who want to strength train without compromise. Designed to work with all types of benches and engineered for extreme workouts. The pull-up bar adds to the finishing touch on this serious piece of kit!



Monkey bar



Bar and plates are not included.



Heavy-duty 13-gauge high tensile strength steel frames feature all-4-side welded construction and oversized industrial strength hardware. Electrostatically applied black powder coat finish resists chipping and scratching through the most brutal routines. If you want to get bigger and stronger fast, a Club Line Power Rack is what you need.

Optional Lat attachment with stacks CLA-380S

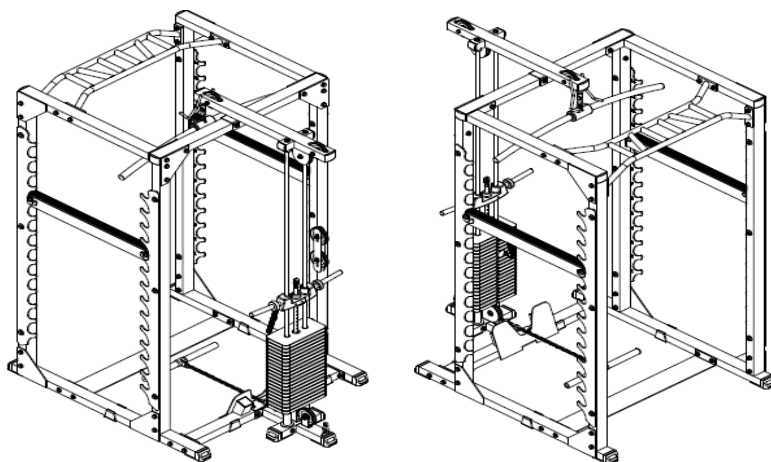

FITNESS MASTER INC.

11419 MATHIS AVENUE #200, FARMERS BRANCH, TX75234

OFFICE & FAX : 214-3508884

TOLL FREE : 855-8460087

EMAIL : info@fmiamerica.com

WEBSITE : www.fmiamerica.com